

The SSB Bar Series Token is a portable data carrier containing 2Kbit to 256Kbit non-volatile, serial SPI EEPROM memory¹ that is completely sealed against moisture and other corrosive elements. Designed to perform in tactical and other harsh environments, the SSB Token is constructed of a rugged material that protects the embedded memory and is resistant to environmental influences such as vibration, ice, dirt, moisture, chemicals, and electrostatic discharge. It features a writable label⁴ and is small enough to be carried in a pocket or to be placed on a keychain or lanyard. The SSB Token is an ideal way to store and transfer data in the harshest environments.

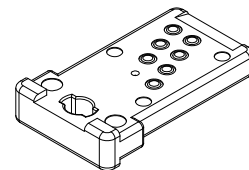

Refer to Bar Receptacle data sheet for pin-out information.

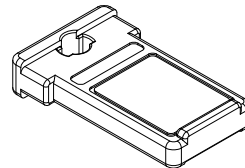
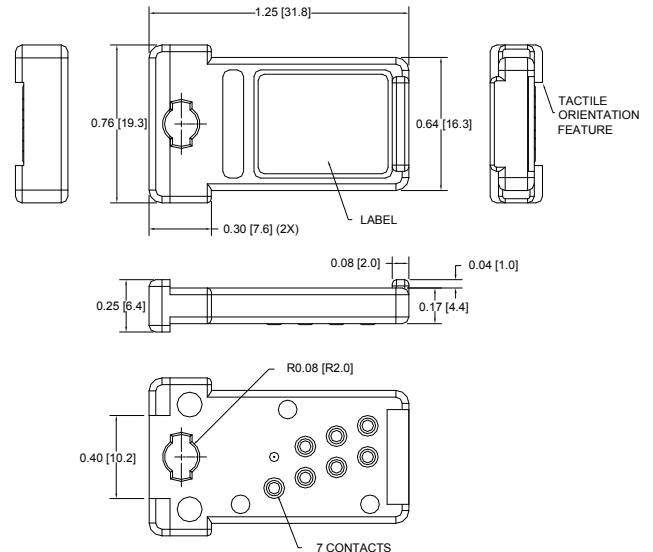

Drawing dimensions are in inches and millimeters [mm].
Dimensions are nominal and subject to manufacturer's tolerances.

Mechanical ²	
Color	Black body with white label
Weight	3.6 g (0.13 ounces), typical
Contact Life	15,000 minimum insertion/removals
Drop Test	Multiple 10-ft drops to concrete
Electrical ¹	
Power, Active	25 milliwatts, typical at 5V
Power, Standby	200 microwatts, typical at 5V
Voltage	2.7V to 5.5V (3.3V recommended) ⁵
ESD Protection	15kV (air discharge) EN 61000-4-2
	EMI Reduction Circuitry on-board
Environmental ²	
Storage Temperature	-40° C to +100° C
Operating Temperature	-40° C to +85° C
Relative Humidity	0% to 95% (non-condensing)
Immersion	MIL-STD-810F, Method 512.4 Proc. I
Salt-Fog	MIL-STD-810F, Method 509.4 Proc. I
Freezing Rain	MIL-STD-810F, Method 521.2 Proc. I; glaze ice
Altitude	≤ 40,000 ft (12,192 meters)
Solar Radiation	MIL-STD-810F, Method 505.4, Proc. II
Other	Contact factory for further information on additional qualification tests (including thermal shock, fungus, & chemical resistance)
Memory ¹	
Capacity	2Kbit(2048 bits), 16Kbit (16,384 bits), 64Kbit (65,536 bits), 256Kbit (262,144 bits)
Read Cycles	Unlimited
Write/Erase Cycles	1,000,000 Minimum
Data Life (Storage)	20 Years Minimum
Mating Component(s) ³	
Bar Receptacle (long pins)	606-0068-000A
Bar Receptacle (short pins)	606-0069-000A
Reader/Writer	Consult factory.
Ordering Information ³	
SSB2Kb	611-0183-000A
SSB16Kb	611-0184-000A
SSB64Kb	611-0185-000A
SSB256Kb	611-0186-000A

NOTES:

- 1: Customers must design to meet Datakey Electronics' SPI EEPROM Interface Specification (p/n 223-0017-004) to provide for future data carrier compatibility. Available at <http://www.datakey.com>.
- 2: See Bar Receptacle datasheet for mechanical and environmental specifications when mated.
- 3: "A" suffix on part number indicates RoHS compliance.
- 4: Compatible with ball point pen (non-erasable), pencil (erasable) and grease pencil (erasable).
- 5: **Design Recommendation:** It is recommended that all new Bar implementations be designed to operate with power supplies in the range of 2.7 to 3.6 volts. Although there is no immediate or certain future difficulties in the procurement of memory devices that operate with V_{cc} in the 4.5 to 5.5 volt range, it is possible the future availability of such memories may be impacted as semiconductor manufacturers continue to shrink their die geometries. Please contact the factory if you have any questions pertaining to this with your current or legacy design.

