

Datakey Electronics large memory capacity serial flash memory Tokens feature a Serial Peripheral Interface (SPI)¹ which is a synchronous serial data link that is standard across many microprocessors and other peripheral chips. It provides a high bandwidth network connection among CPUs and other devices supporting the SPI-compatible bus. The primary applications are data logging, firmware updates, and data transfer. The memory can be written or programmed 1 to 256 bytes at a time, using the Page Write or Page Program instructions. Refer to the SPI Interface Specification for specific sector and page information. The SFT Series features Datakey Electronics industry-leading solid molded construction, rugged wear-resistant exterior and long-lasting contacts.

Mechanical	
Contact Life	10,000 Insertions/Removal Cycles Min.
Contact Arrangement	Fully Redundant (Front:Back)
Electrical ¹	
Power, Active	25 milliwatts typical
Power, Standby	550 microwatts typical
Voltage	2.7 to 3.6V
ESD Protection	15kV (per Std. 064-1028)
Environmental	
Storage Temperature	-40° C to + 100° C
Operating Temperature	-40° C to + 85° C
Relative Humidity	5% to 95% (non-condensing)
Memory ¹	
Token:	Capacity:
SFT1Mb	1,048,576 bits (131,072 bytes)
SFT2Mb	2,097,152 bits (262,144 bytes)
SFT4Mb	4,194,304 bits (524,288 bytes)
SFT8Mb	8,388,608 bits (1,048,576 bytes)
Read Cycles	Unlimited
Write/Erase Cycles	100,000 Cycles Minimum
Data Life (Storage)	20 Year Data Retention
Mating Component(s)	
Panel-Mount Receptacle	SR4210
PCB Mount Receptacle	SR4000 Family of Receptacles
Reader/Writer	SlimLink™ III (recommended), SlimLink™ II
Ordering Information ²	
SFT1Mb	611-0106-00XA
SFT2Mb	611-0092-00XA
SFT4Mb	611-0093-00XA
SFT8Mb	611-0166-00XA

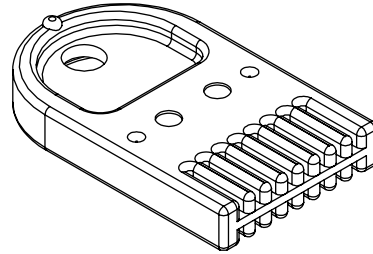

For pin-out information, refer to the individual data sheets for the SR4000 Family of Receptacles.

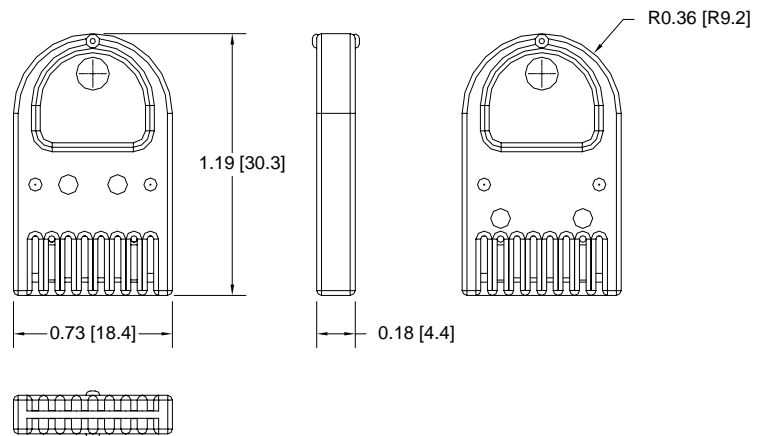

Drawing dimensions are in inches and millimeters [mm]. Dimensions are nominal and subject to manufacturer's tolerances.

NOTES:

- 1: Complete SPI Interface Specification available at http://www.datakeyelectronics.com/technical_inter_specs.html
- 2: "X" indicates optional color number-contact factory. "A" suffix on part number indicates RoHS compliance.

