

Datakey Electronics, Inc. – Product Change Notification (PCN)

PCN Number: 20091216

Notice Date: December 16, 2009

Notification Subject: Change in enclosures for KeyLink/SlimLink series reader/writers

Datakey Electronics Products Affected:

KeyLink IIs, KeyLink IIsE, KeyLink IIsU, KeyLink III, SlimLink IIs, SlimLink IIsE, SlimLink IIsU, SlimLink III.

Note: PCN applies to all standard and custom versions of these parts.

Datakey Electronics Standard Part Numbers Affected:

607-0065-XXX(A), 607-0068-XXX(A), 607-0078-XXX(A), 607-0079-XXX(A), 607-0080-XXX(A).

Description of Change:

The reader/writer enclosure will be changed. The current enclosure (2.31”(w) x 3.74”(l) x 1.20”(h) – snap-fit) is being obsoleted and replaced with a new enclosure (3.09”(w) x 3.90”(l) x 1.40”(h) – screw fasteners).

See sketches below.

This change affects the overall appearance only – no functionality of the reader/writers is being changed as part of this PCN. All product markings, details, and available label space will be transferred to the new enclosure.

Reason for Change:

Improve manufacturability. Maintain constant price level.

Change Implementation Status:

In progress. Shipments of Reader/Writers with the new enclosure will be phased in during 2010. Exact timing dependent on individual model.

Impacts to Data Sheet:

Drawings will be updated. No change to part numbers.

Notes:

Contact the factory (+1-952-746-4066 / 800-328-8828) Ext. 348, if you have any questions or concerns on this PCN.

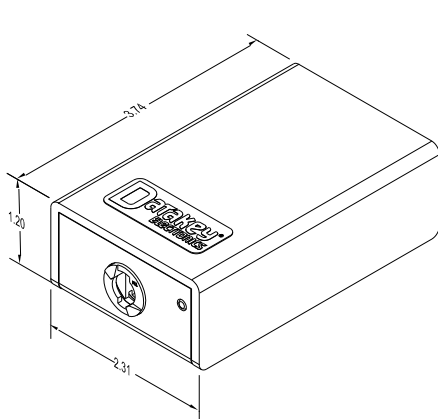

Current Reader/Writer Enclosure Box

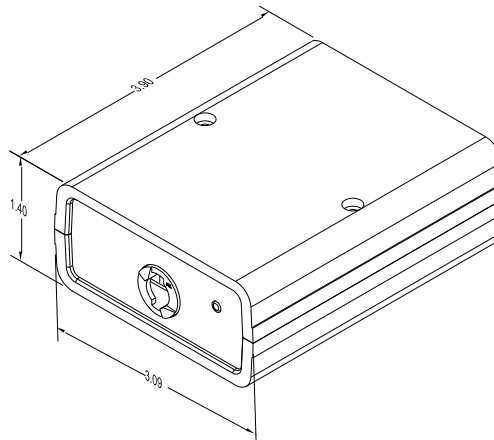

New Reader/Writer Enclosure Box

Note: KeyLink (Key) version shown – Dimensions apply to SlimLink (Token) version as well.