

The KC4210PCB Keyceptacle access device is a space-saving interface connector for all Datakey Electronics' serial memory Keys. Designed to mount directly onto your printed circuit board, it is more compact than the panel-mount Keyceptacle and requires less front panel space. Like all Datakey Electronics access devices, the KC4210PCB provides reliable connection over a long operating life. It is rated for a minimum of 200,000 Key insertions and removals. The KC4210PCB also contains a Last-On/First-Off (LOFO) switch that may be used to protect the host bus by ensuring that Keys have made secure contact with the Keyceptacle before any signals are transmitted.

Mechanical	
Operating Torque	85 m Nm (12 ounce-inch) maximum
Operating Life	200,000 insertion/removal cycles (min.)
Key Stop Sustaining Torque	1.7 Nm (15 inch-pounds)
Electrical	
Contact Resistance	Beginning of Life: 100 mΩ
	End of Life: 500 mΩ
Environmental	
Storage Temperature	-40° C to + 105° C
Operating Temperature	-40° C to + 80° C
Relative Humidity	5% to 95% (non-condensing)
Mating Component(s)	
Keys	All Serial Key Series
Ordering Information ¹	
KC4210PCB ³	606-0053-000A

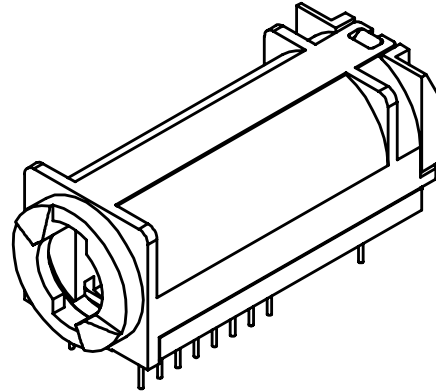

See next page for mechanical drawings.

NOTES:

- 1: "A" suffix on part number indicates RoHS compliance.
- 2: Complete Interface Specifications available at:
http://www.datakeyelectronics.com/technical_inter_specs.html
- 3: The Keyceptacle is also available in a panel-mount version (see KC4210).
- 4: RST signal used on I1K Series only.

Pin-Out Chart ²			
Pin #	Microwire	I ² C	SPI
1	NC	SIZE / RST ⁴	/Hold
2	Ground (V _{SS})	Ground (V _{SS})	Ground (V _{SS})
3	Power (V _{CC})	Power (V _{CC})	Power (V _{CC})
4	NC	NC	NC
5	Data Out (DO)	Serial Data/Add (SDA)	Data Out (DO)
6	Chip Select (CS)	NC	/Chip Select (/CS)
7	Serial Clock (SK)	Serial Clock (SK)	Serial Clock (SK)
8	Data In (DI)	NC	Data In (DI)
9	Data In (DI)	NC	Data In (DI)
10	Serial Clock (SK)	Serial Clock (SK)	Serial Clock (SK)
11	Chip Select (CS)	NC	/Chip Select (/CS)
12	Data Out (DO)	Serial Data/Add (SDA)	Data Out (DO)
13	NC	NC	NC
14	Power (V _{CC})	Power (V _{CC})	Power (V _{CC})
15	Ground (V _{SS})	Ground (V _{SS})	Ground (V _{SS})
16	NC	SIZE / RST ⁴	/Hold
17	LOFO	LOFO	LOFO
18	LOFO	LOFO	LOFO

NC=No Connection



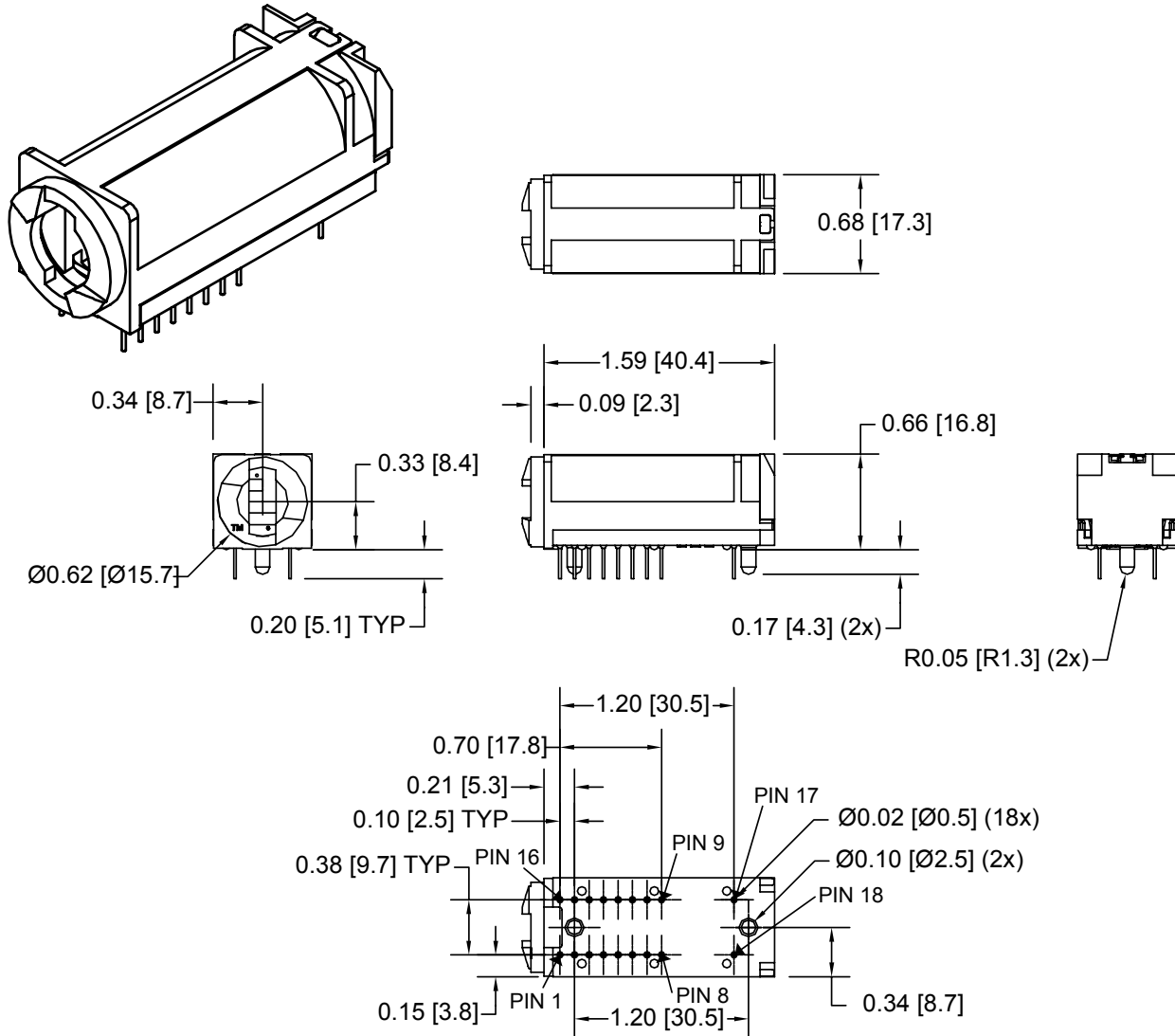

Keyceptacle pin-out as viewed from bottom side, reference only.

Solder Pin Length 0.200" [5.08]
Diameter 0.018" [0.46]

Drawing dimensions are in inches and millimeters [mm]. Dimensions are nominal and subject to manufacturer's tolerances.

