

Datakey Electronics' IEX Series of CryptoMemory¹ Extended Tokens incorporate the highly secure symmetric dynamic mutual authentication protocols provided by Atmel Corporation's CryptoMemory products. Encrypted passwords, mutual authentication, data encryption, and encrypted checksums provide extremely high levels of data security. Datakey Electronics' IEX Series of Extended Tokens are compliant with the Atmel 2-wire protocol and is available with user EEPROM memory capacities of 1Kbit to 256Kbit. The IEX Series features Datakey Electronics' industry-leading solid molded construction, rugged wear-resistant exterior and long-lasting contacts. These Tokens interface to Datakey Electronics' standard SlimLine™ Token Receptacles—consult factory.

Mechanical	
Contact Life	10,000 Insertions/Removal Cycles Min.
Contact Arrangement	Fully Redundant (Front:Back)
Electrical	
Power, Active	25 milliwatts typical at 5V
Power, Standby	200 microwatts typical at 5V
Voltage ²	2.7 to 5.5V
ESD Protection	15kV (per Std. 064-1028)
Environmental	
Storage Temperature	-40° C to + 100° C
Operating Temperature	-40° C to + 85° C
Relative Humidity	5% to 95% (non-condensing)
Memory	
Token	Capacity:
IEX1Kb	1Kb (1,024 bits) 128 x 8
IEX16Kb	16Kb (16,384 bits) 2048 x 8
IEX64Kb	64Kb (65,536 bits) 8192 x 8
IEX256Kb	256Kb (262,144 bits) 32768 x 8
Read Cycles	Unlimited
Write/Erase Cycles	100,000 Cycles Minimum
Data Life (Storage)	10 Years Minimum
Mating Component(s)	
Panel-Mount Receptacle	SR4210
PCB Mount Receptacle	SR4000 Family of Receptacles
Ordering Information	
IEX1000	Consult factory.
IEX16000	Consult factory.
IEX64000	Consult factory.
IEX256K	Consult factory.

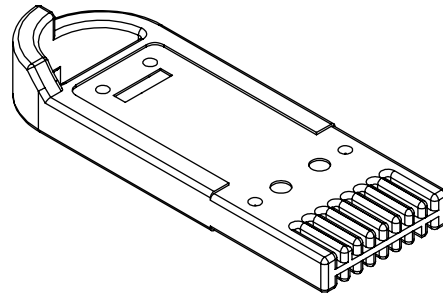

Consult factory for pin-out information.

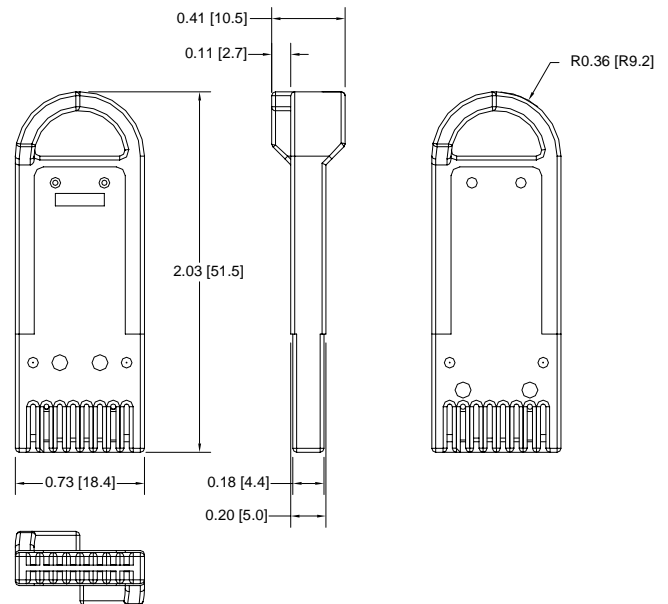

NOTES:

- 1: CryptoMemory is a registered trademark of Atmel Corporation and is used by permission.
- 2: **Design Recommendation:** It is recommended that all new Key/Token implementations be designed to operate with power supplies in the range of 2.7 to 3.6 volts. Although there is no immediate or certain future difficulties in the procurement of memory devices that operate with V_{cc} in the 4.5 to 5.5 volt range, it is possible the future availability of such memories may be impacted as semiconductor manufacturers continue to shrink their die geometries. Please contact the factory if you have any questions pertaining to this with your current or legacy design.

Drawing dimensions are in inches and millimeters [mm]. Dimensions are nominal and subject to manufacturer's tolerances.

